



Dehumidifiere KPS-180

Swimming pool dehumidifier

Control the relative humidity of the air inside is especially appreciated in the local pool or locker rooms because, especially in autumn and winter, condensation problems are very often extremely serious. In addition to use in swimming pools, shower rooms and locker rooms, our machines are excellent applications in gyms, dance halls and generally in all the structures used to sport. The activity of the athletes in fact more or less frequent than the use of local showers and changing rooms of gyms inevitably leads to an excess of humidity in the air resulting in deterioration of equipment and furnishings. Machine characterized by high reliability and high performance in terms of capacity of condensation, and then slaughter the relative humidity inside the premises. Dehumidifier particularly suitable for heavy duty, or when necessary to treat large quantities of air. Peculiarities of our machine is the particular positioning that can be done either to the floor or wall with appropriate mounting system. Now available in two versions: home accessories and duct system.

Description

Furnishing dehumidifier employed in indoor swimming pools, saunas, turkish baths, wellness centres and hotels swimming pools. The device has an electronic control defrosting, low noise and low energy consumptions. The structure is entirely made of galvanized steel and coated for durability and long-lasting excellent performances; moreover the eco-friendly refrigerant gas R410 respects the environment. This dehumidifier has a polished and fine aspect which is suitable for every room design. It can be installed in three different ways: floor installation, wall installation and duct installation. The dehumidifier must be installed following the current regulations.



con gas 100%
ecologico **R410A**

Accessories:

- Hot water batteries
- On-board or remote humidistat
- Electric post heating kit
- Ducted intake air supply
- Stand for floor installations

Versions

- Version with furniture case
- Ducted version

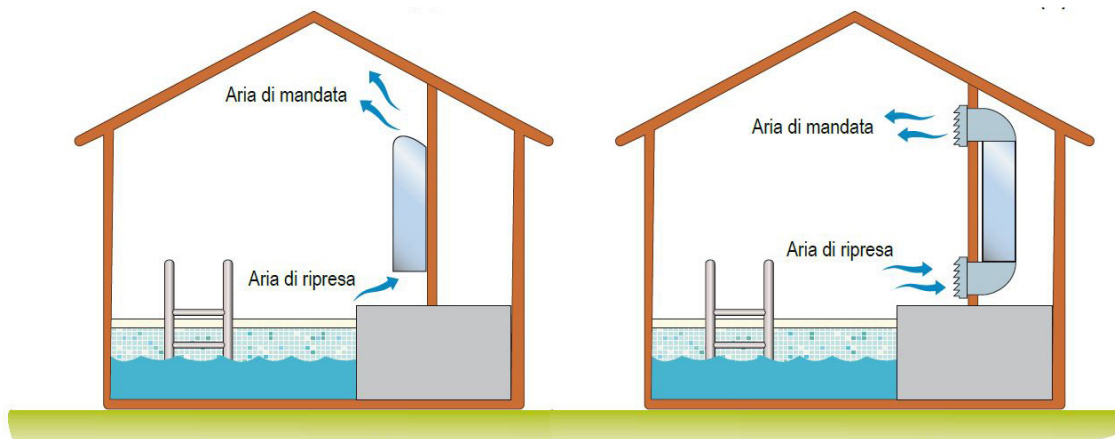

Version with furniture case

Ducted version

Types of installations

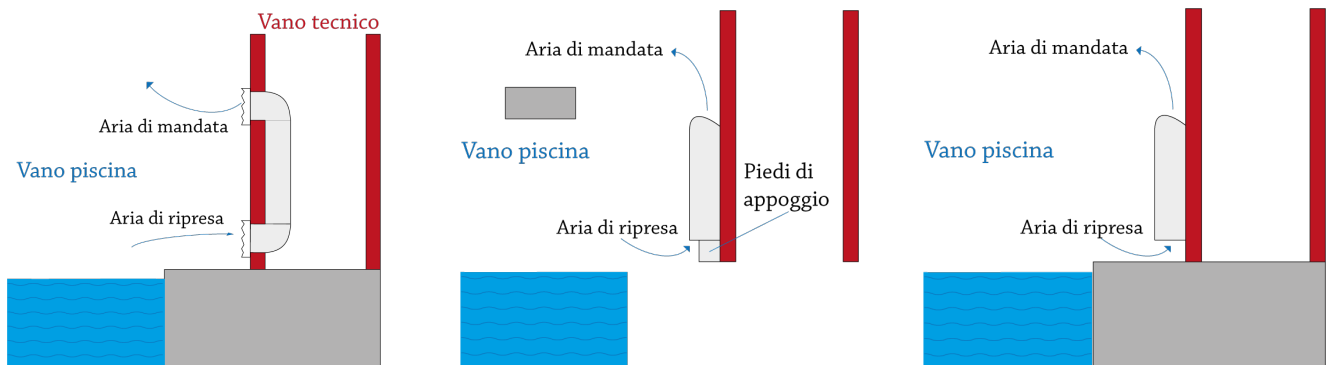

DUCT INSTALLATION

FLOOR INSTALLATION

WALL INSTALLATION

Technical data

Condensation capacity (35°C, 80% R.H.)	180 lt/24h
Refrigerant	R410A
Humidity removed at 30°C - 80%	155,0 l/24h
Humidity removed at 30°C - 60%	133,1 l/24h
Humidity removed at 27°C - 60%	96,6 l/24h
Humidity removed at 20°C - 60%	71,5 l/24h
Total absorbed power (1)	1,9 kW
Maximum power absorbed (1)	2,3 kW
Maximum power absorbed (2)	8,7 kW
Integrative electrical resistance	6 kW
Maximum absorbed current (1)	10,5 A
Maximum absorbed current (2)	38 A
Hot water battery (3)	11,5 kW

Air flow	1400 m3/h
Useful static prevalence	40 Pa
Sound pressure level (1 mt according to ISO3746)	52 dB(A)
Operating range (temperature)	20 - 36 °C
Operating range (relative humidity)	50 - 99 %
Weight	72 Kg
Voltage	230/1/50 V/Ph/Hz

- (1) Without electrical resistance.
- (2) With electrical resistance help.
- (3) Ambient temperature 30 ° C; water temperature 80/70 ° C, compressor off.
- (4) Power values calculated according to ISO 9614.
- (5) Sound pressure values measured at 1 mt distance from the unit in free field according to ISO 9614.

Dimensional

KPS 180 with furniture case	
Height	836 mm
Width	1310 mm
Depth	310 mm
Weight	99 Kg

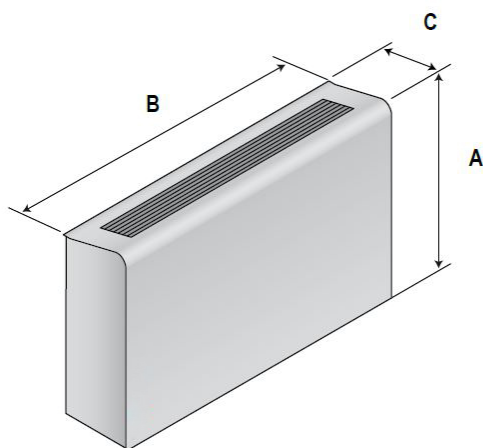

KPS-180 (Ducted version)	
Height	770 mm
Width	1255 mm
Depth	300 mm
Weight	82 mm

